

Heart Rate Kit Installation Instructions: APOLLO / NEON / VIKING / OMEGA

Contents:

A. HR Receiver 5.0KHz(1)

B. Cable Tie Mounts(3)

C. Cable Tie (3)

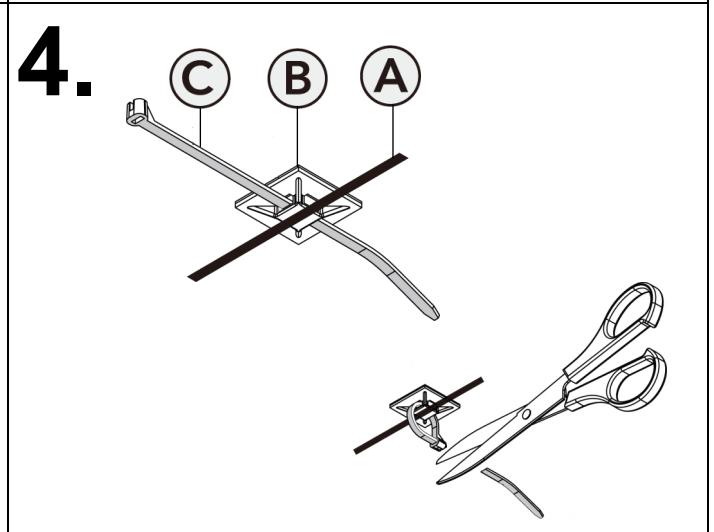
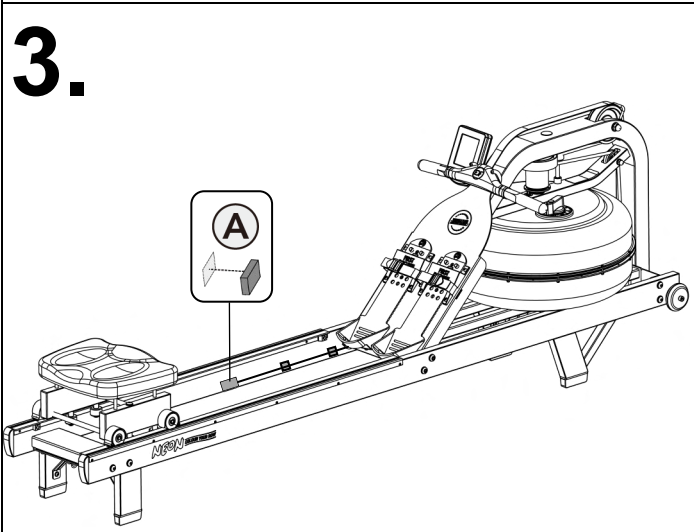
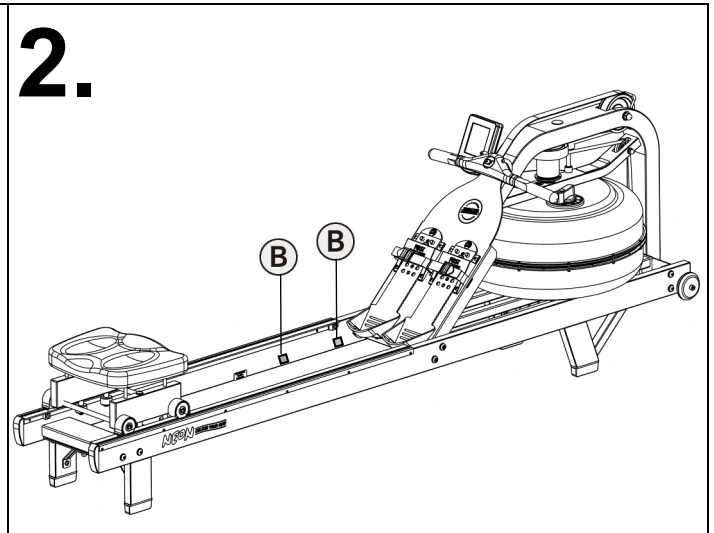
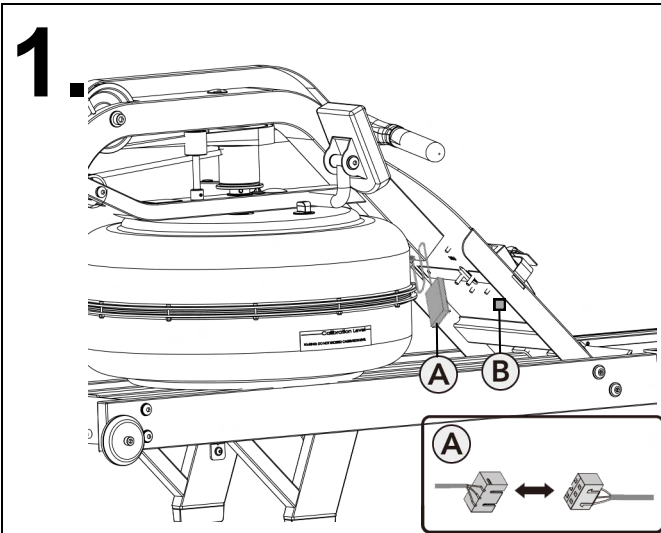
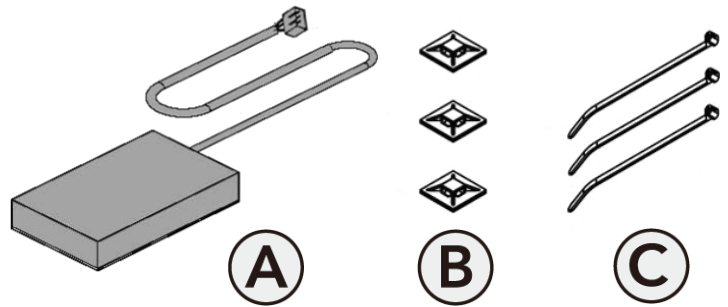

To display heart rate requires a First Degree Fitness long range strap (sold separately) Polar™ or other compatible brand chest strap transmitter available from your dealer.

Notes: Maintaining a consistent signal on a rower can be a challenge due to the varying distances experienced during the rowing stroke between the Receiver/Transmitter.

If you are experiencing difficulty, make sure the batteries on your chest belt or other device are fresh, and that the frequency of your transmitter is 5KHz.

Environmental conditions, as well as proximity to other machines can also interfere with a clean signal.

Feel free to experiment with different locations for best performance.