

# ARM CYCLE E650

## STANDING UPPER BODY ERGOMETER



# FLUID EXERCISE



The E650 Arm Cycle, Standing Upper Body Ergometer is a high quality commercial grade Arm Cycle designed to withstand the loads of high intensity powerful workouts or provide silky smooth resistance suitable for warm ups, cool downs and rehabilitation.

The E650 resistance is set via our patented 10 x Adjustable Fluid Resistance Twin Tank system and the RPM is driven by you. The Arm Cycle is capable of handling the ballistic speeds of a HIIT workout and yet will remain smooth and consistent at very low RPM. This wide variation in load and speed capabilities allows you to train effectively to any workout program.

The ground based E650 Arm Cycle movement involves long kinetic chains engaging many muscles from the ground up. Your core is activated to support your entire shoulder girdle when engaged in the arm cycle motion. The E650 provides load in either direction. Changing direction alters the emphasis on the muscles engaged, adding even more variety to your training.

The E650 is a perfect inclusion for any type of fitness facility. It can add variety to all types of group training, is a perfect warm up tool with a focus on the core and upper body and only takes up a little over 1sqm [11sqft].

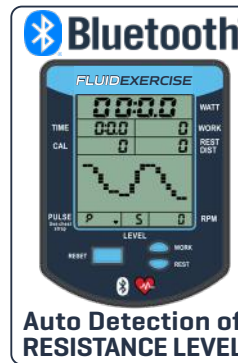

View the full range of Upper Body Ergometers at [FLUIDEXERCISE.COM](http://FLUIDEXERCISE.COM)

Visit [FIRSTDEGREEFITNESS.COM](http://FIRSTDEGREEFITNESS.COM) to view all FDF product ranges.

# ARM CYCLE E650 FLUIDEXERCISE

## PRODUCT SPECIFICATIONS

PRODUCT MODEL NO:	E650
FLUID RESISTANCE:	Vertical FDF Twin Tank - 10 levels
MONITOR:	FDF Bluetooth / Heart Rate Compatible
PRODUCT NET WEIGHT:	73.23kg [161.39lb]
PRODUCT GROSS WEIGHT:	86.85kg [191.47lb]
DIMENSIONS:	L 1,340mm [52.8"] x W 750mm [29.5"] x H 1,348mm [53"]
MIN ACTIVE AREA REQUIRED:	L 2,450mm [100.00"] x W 1,950mm [76.77"]
MAX USER WEIGHT:	150kg [330.00lb]
ARM CRANK LENGTH:	185mm [7.3"]
COMMERCIAL WARRANTY:	Frame 10 years - Polycarbonate Tank & Seals - Lifetime Warranty Mechanical & Other Non-Wearing Components - 2 Year Limited Warranty All Other Components (of a wearing nature) - 1 Year Limited Warranty Refer to website for full warranty terms and conditions.



## CONSOLE FEATURES

- + Bluetooth Connectivity using BT FTMS protocol
- + Bluetooth Heart Rate Monitor [HRM] compatible
- + Auto start
- + Time - Elapsed time
- + Level - Auto to selected resistance level
- + Watt - Unit of power
- + Work - Interval Duration
- + Rest Interval
- + Distance
- + RPM - Revolutions per minute
- + Power Graphs - 2 Options
- + Calories burned per hour



ERGONOMIC ROTATING HAND GRIPS

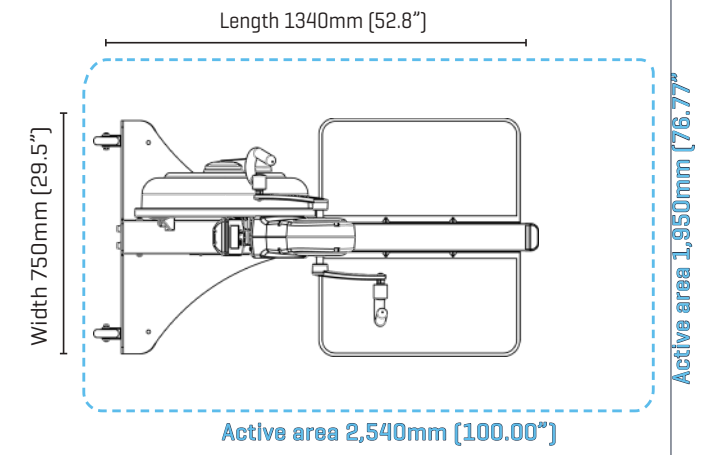

## ABOUT FDF (FIRST DEGREE FITNESS)

FDF is the leader in designing and manufacturing a range of adjustable Fluid Resistance fitness machines for commercial and residential applications. At the heart of the fitness range is our unique and patented Twin Tank Fluid Resistance system. The adjustable Fluid Resistance system challenged the conventional thinking of how water could work to provide adjustable resistance rather than just a liquid mass flywheel. The patented Twin Tank system provides silky smooth resistance at any speed and is perfect for cardio training, warm-ups, cool downs, intense HIIT workouts or rehabilitation programs. FDF categorizes the range of adjustable Fluid Resistance machines under the banners, **FluidRower**, **FluidExercise** and **FluidPowerZone**, see the adjacent web links. FDF products are distributed throughout the globe and are popular in Fitness Centers, Hotels and Apartments, Sporting Clubs, Universities, First Responders, Defence Force Training Facilities and Physical Rehabilitation Clinics.

\* FDF reserves the right to modify any product design, manufacture or aesthetic without notice or consultation. Product specifications and warranties may vary from country to country.



View all product ranges at  
[FLUIDROWER.com](http://FLUIDROWER.com)

[FLUIDEXERCISE.com](http://FLUIDEXERCISE.com)  
[FLUIDPOWERZONE.com](http://FLUIDPOWERZONE.com)

**FLUIDROWER**



**FLUIDPOWERZONE**



**FLUIDEXERCISE**

