

# RESISTANCE PLATFORM

## FUNCTIONAL CONCENTRIC TRAINING PLATFORM



# FLUID EXERCISE



The FDF FluidExercise RESISTANCE PLATFORM is an industrial quality, ground-based, adjustable Fluid Resistance functional concentric training platform.

The concentric only resistance of the RESISTANCE PLATFORM is delivered by our 10 levels of Adjustable Fluid Resistance provided by our patented Twin Tank system. The semi isokinetic nature of the Adjustable Fluid Resistance allows for powerful explosive movements without generating momentum. You control the resistance, you control the speed and you control the range of motion to allow you to safely train in any zone; Cardio, Power, Strength or Speed.

The RESISTANCE PLATFORM is designed to support complex lifting routines without the force of accelerated weight on the way back down, providing a suitable workout platform for sports or rehabilitation applications. The RESISTANCE PLATFORM offers all the benefits of Olympic Bar and Kettlebell training without the associated risks of decelerating or lowering the weights.

As with all FluidExercise machines, the RESISTANCE PLATFORM incorporates our patented Twin Tank and expands on that with 3 separate resistance attachment options, offering concentric loads at 50%, 100% and 200% of the tank settings. The biggest and strongest muscles across the posterior chain are challenged at the high load setting (200%) and complex light resistance movements are ideally accommodated for at the lower load setting (50%). The range of options allows you to train at the correct load and at high volumes, all without overloading.

The RESISTANCE PLATFORM includes an attachment accessory pack consisting of Squat Belt, Single Handle Strap, Ankle Strap and swivel Straight Bar, all stored on the inbuilt accessory rack. See the glossary of main exercises below.

The FluidExercise RESISTANCE PLATFORM is a perfect inclusion for any type of fitness facility, it can open up a range of exercise options once only available to a skilled athlete. The RESISTANCE PLATFORM will add variety to all types of training and can be combined with other FluidExercise machines to create a stand alone, ground based functional trainer.

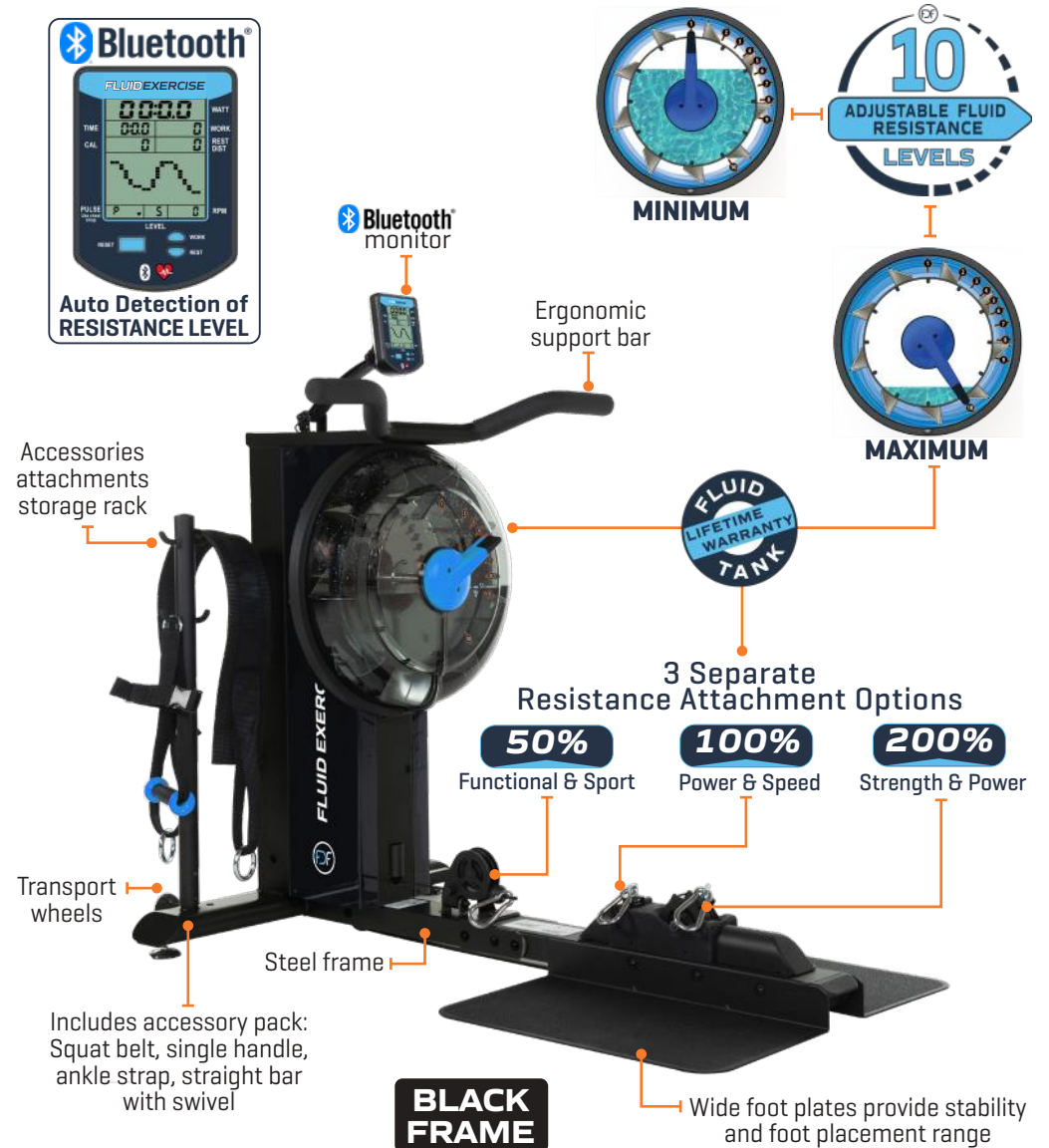

View the full range of Upper Body Ergometers at [FLUIDEXERCISE.COM](https://www.fluidexercise.com)

Visit [FIRSTDEGREEFITNESS.COM](https://www.firstdegreefitness.com) to view all FDF product ranges.

# FLUIDEXERCISE RESISTANCE PLATFORM

## 3 SEPARATE RESISTANCE ATTACHMENT OPTIONS

### 50%

#### FUNCTIONAL & SPORT

- + 50% of selected tank resistance
- + Diagonal and kettlebell patterns, rehabilitation, upper and lower extremity, abduction / adduction, extension / flexion

### 100%

#### POWER & SPEED

- + 100% of selected tank resistance
- + High pulls, jump squat and one arm clean press

### 200%

#### STRENGTH & POWER

- + 200% of selected tank resistance
- + Squats, deadlifts, bent rows and Olympic lifting movement



**INCLUDES ACCESSORY PACK**

- + Squat belt, single handle, ankle strap, straight bar with swivel

# FLUIDEXERCISE

## RESISTANCE PLATFORM EXERCISES

SQUAT



DEADLIFT



HIGH PULL



BENT ROW



FRONT SQUAT



HIGH SHRUG



ROMANIAN DEADLIFT



DIAGONAL LIFT



ONE ARM CLEAN PRESS



KETTLEBELL SWING



DIAGONAL SWING



ONE ARM ROW



JUMP SQUAT



# RESISTANCE PLATFORM

# FLUIDEXERCISE

## PRODUCT SPECIFICATIONS

PRODUCT MODEL NO:	FE-CUB
FLUID RESISTANCE:	Vertical FDF Twin Tank - 10 levels
MONITOR:	FDF Bluetooth / Heart Rate Compatible
PRODUCT NET WEIGHT:	81.5kg [179.68lb]
PRODUCT GROSS WEIGHT:	95.6kg [210.76lb]
DIMENSIONS:	L 1,450mm [57.1"] x W 830mm [31.7"] x H 1,350mm [53.2"]
MIN ACTIVE AREA REQUIRED:	L 2,650mm [104.33"] x W 2,030mm [79.92"]
MAX USER WEIGHT:	180kg [396.8lb]
VERTICAL SPACE:	H 2,150mm [84.6"]
COMMERCIAL WARRANTY:	Frame 10 years - Polycarbonate Tank & Seals - Lifetime Warranty Mechanical & Other Non-Wearing Components - 2 Year Limited Warranty All Other Components (of a wearing nature) - 1 Year Limited Warranty Refer to website for full warranty terms and conditions.



## CONSOLE FEATURES

- + Bluetooth Connectivity using BT FTMS protocol
- + Bluetooth Heart Rate Monitor (HRM) compatible
- + Auto start
- + Time - Elapsed time
- + Level - Auto to selected resistance level
- + Watt - Unit of power
- + Work - Interval Duration
- + Rest Interval
- + Distance
- + RPM - Revolutions per minute
- + Power Graphs - 2 Options
- + Calories burned per hour

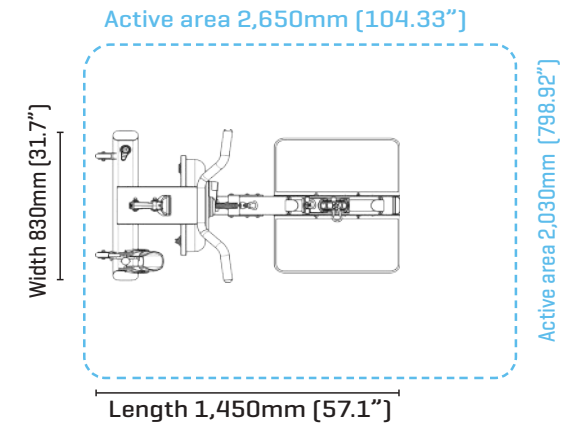
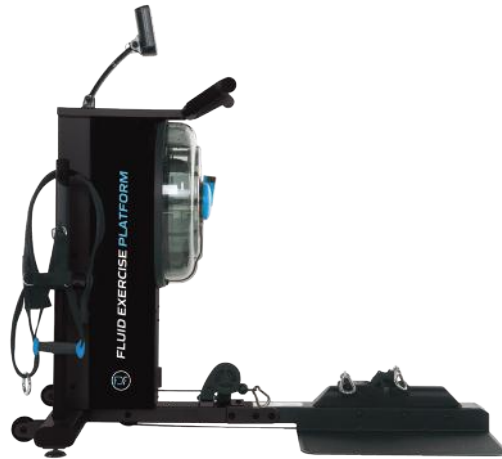

## ABOUT FDF (FIRST DEGREE FITNESS)

FDF is the leader in designing and manufacturing a range of adjustable Fluid Resistance fitness machines for commercial and residential applications. At the heart of the fitness range is our unique and patented Twin Tank Fluid Resistance system. The adjustable Fluid Resistance system challenged the conventional thinking of how water could work to provide adjustable resistance rather than just a liquid mass flywheel. The patented Twin Tank system provides silky smooth resistance at any speed and is perfect for cardio training, warm-ups, cool downs, intense HIIT workouts or rehabilitation programs. FDF categorizes the range of adjustable Fluid Resistance machines under the banners, **FluidRower** and **FluidExercise**, see the adjacent web links. FDF products are distributed throughout the globe and are popular in Fitness Centers, Hotels and Apartments, Sporting Clubs, Universities, First Responders, Defence Force Training Facilities and Physical Rehabilitation Clinics.

\* FDF reserves the right to modify any product design, manufacture or aesthetic without notice or consultation. Product specifications and warranties may vary from country to country.



View all product ranges at  
[FLUIDROWER.com](http://FLUIDROWER.com)

[FLUIDPOWERZONE.com](http://FLUIDPOWERZONE.com)

### FLUIDROWER



### FLUIDEXERCISE



# RESISTANCE PLATFORM

## FUNCTIONAL CONCENTRIC TRAINING PLATFORM

