

# NEON PRO PLUS BLACK

## COMMERCIAL FLUIDROWER



# FLUID ROWER



The **FDF NEON Pro Plus FluidRower** is a commercial grade rowing ergometer with an instant natural catch and a smooth, consistent feel through the whole rowing stroke.

The NEON Pro Plus has 4 levels of Adjustable Fluid Resistance provided by our patented Twin Tank system. At level 1 the Fluid Resistance is suitable for beginners, deconditioned participants or rehabilitation patients just starting on their fitness journey. Dial to level 4 for high-intensity interval training (HIIT) or short sprints.

The sculpted steel frame that wraps around twin tank makes a stable rowing platform as well as a luxurious modern style.

The elevated NEON Pro Plus makes it for easy on and off access for all users. This ease of access is essential for quick changes during circuit rowing classes and important in commercial fitness facilities.

It's light enough to be moved between rooms and easy to store upright when not in use.

The NEON FluidRower series is available in bright green, yellow and orange coloured frame options.

### NEON SERIES AVAILABLE IN



### COMPACT CLASS STORAGE



MINIMUM



ADJUSTABLE FLUID RESISTANCE LEVELS



MAXIMUM

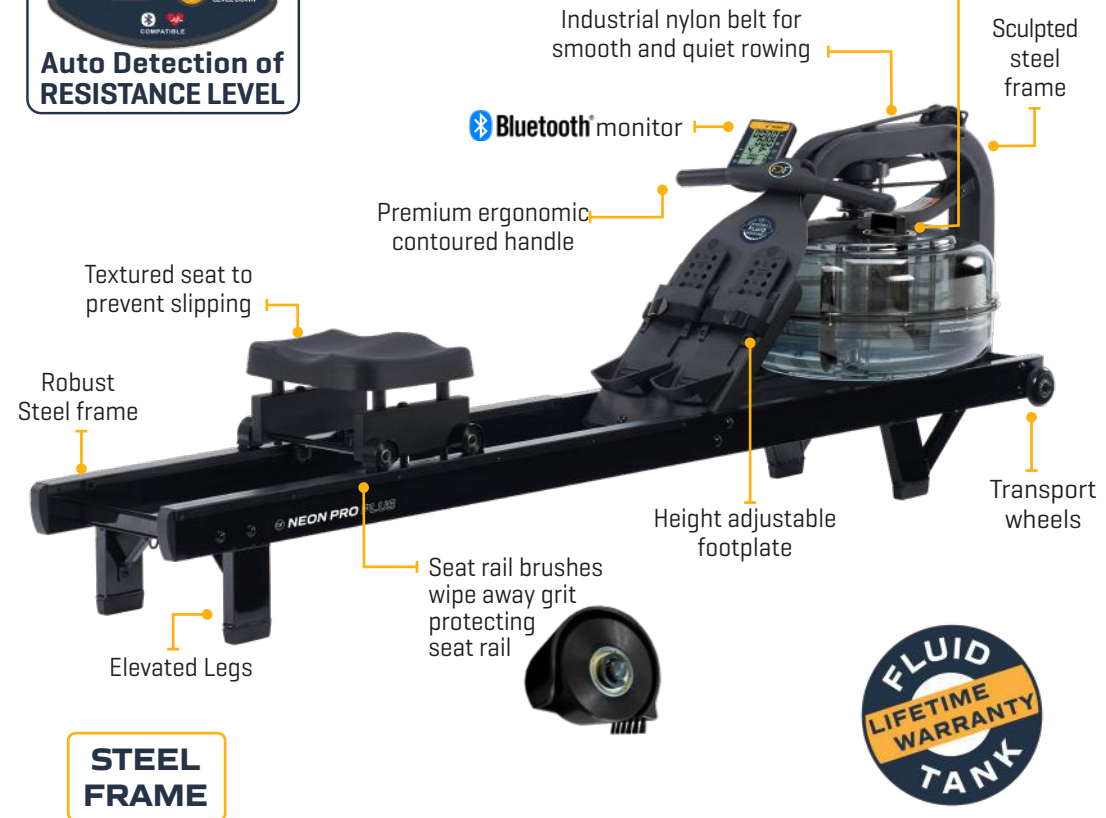

**STEEL FRAME**



View the full range of rowers at [FLUIDROWER.COM](https://www.fluidrower.com)  
 Visit [FDFLIMITED.COM](https://www.fdflimited.com) to view all FDF products ranges.



# NEON PRO PLUS BLACK FLUIDROWER

## PRODUCT SPECIFICATIONS

PRODUCT MODEL NO:	EPBP
FLUID RESISTANCE:	Horizontal FDF Twin Tank - 4 Levels
MONITOR:	FDF  Bluetooth/ Heart Rate Compatible
PRODUCT NET WEIGHT:	39.14kg [86.28lb]
PRODUCT GROSS WEIGHT:	44.35kg [97.78lb]
DIMENSIONS:	L 2,160mm [85.04"] x W 520mm [20.47"] x H 680mm [26.77"]
MIN ACTIVE AREA REQUIRED:	L 3,330mm [131.09"] x W 1,720mm [67.71"]
STORED VERTICAL DIMENSIONS:	L 680mm [26.77"] x W 540mm [21.25"] x H 2,130mm [85.03"]
MAX USER WEIGHT:	150kg [330lb]
COMMERCIAL WARRANTY:	Frame 10 years - Polycarbonate Tank & Seals - Lifetime Warranty Mechanical & Other Non-Wearing Components - 2 Year Limited Warranty All Other Components (of a wearing nature) - 1 Year Limited Warranty Refer to website for full warranty terms and conditions.



## CONSOLE FEATURES

- +  Bluetooth® Connectivity using BT FTMS protocol
- +  Bluetooth® Heart Rate Monitor [HRM] compatible
- + Auto start
- + Time - Elapsed time
- + Level - Manually selected resistance level
- + 500M Time - Time to row 500 meters
- + Watt - Unit of power per stroke
- + Distance - Updated every second
- + SPM - Strokes per minute
- + Calories burned per hour

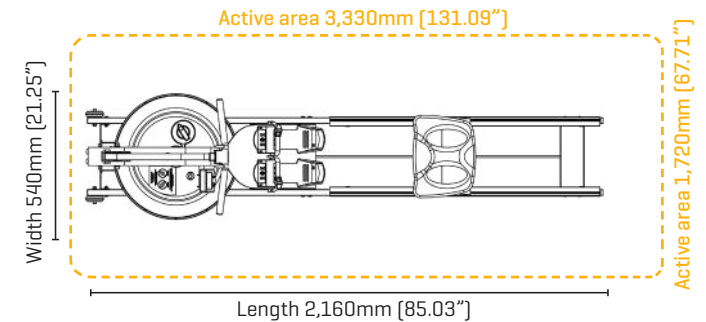

## ABOUT FDF LIMITED

**FDF Limited** is the leader in designing and manufacturing a range of adjustable Fluid Resistance fitness machines for commercial and residential applications. At the heart of the fitness range is the unique and patented Twin Tank Fluid Resistance system. The adjustable Fluid Resistance system challenged conventional thinking of how water could work to provide adjustable resistance rather than just a liquid mass flywheel. The patented Twin Tank system provides silky smooth resistance at any speed and is perfect for cardio training, warm-ups, cool downs, intense HIIT workouts or rehabilitation programs. **FDF Limited** categorizes the range of adjustable Fluid Resistance machines under the banners, **FluidRower**, **FluidExercise** and **FluidPowerZone**, see the adjacent web links. **FDF Limited** products are distributed throughout the globe and are popular in Fitness Centers, Hotels and Apartments, Sporting Clubs, Universities, First Responders, Defence Force Training Facilities and Physical Rehabilitation Clinics.

## OPTIONAL FLUIDROWER ACCESSORIES



TABLET HOLDER



SEAT BACK KIT



View all FDF products at [FLUIDROWER.com](https://www.fluidrower.com) [FLUIDEXERCISE.com](https://www.fluidexercise.com) [FLUIDPOWERZONE.com](https://www.fluidpowerzone.com)

\* FDF reserves the right to modify any product design, manufacture or aesthetic without notice or consultation. Product specifications and warranties may vary from country to country.