

NEON PRO V BLACK

COMMERCIAL FLUIDROWER

The **FDF NEON Pro V FluidRower** is a commercial grade rowing ergometer with an instant natural catch and a smooth consistent feel through the whole rowing stroke. The adjustable fluid resistance is created by the unique semi isokinetic properties of our patented Twin Tank, 5 level Adjustable Fluid Resistance system.

The elevated seat height of the NEON Pro V makes for easy on and off access for all users. This ease of access is essential for quick changes during circuit rowing classes and important in all commercial fitness facilities.

The NEON Pro V will accommodate all levels and abilities from general fitness, to elite athletes, and is ideally suited for rehabilitation and medical applications.

The NEON Pro V FluidRower has a unique clean line robust design with the central horizontal Fluid Resistance Twin Tank, a convenient height rowing seat and a comparatively short frame length.

The attractive design provides practical benefits for easy access and minimal floor space requirements. It is light enough to be moved between rooms or stored upright when not in use. Every commercial fitness facility needs a rowing machine and the Neon Pro V FluidRower is an ideal inclusion.

COMPACT CLASS STORAGE



FLUIDROWER



Auto Detection of RESISTANCE LEVEL



MINIMUM



ADJUSTABLE FLUID RESISTANCE LEVELS

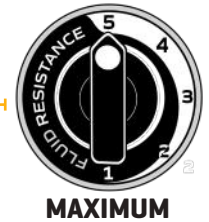

MAXIMUM

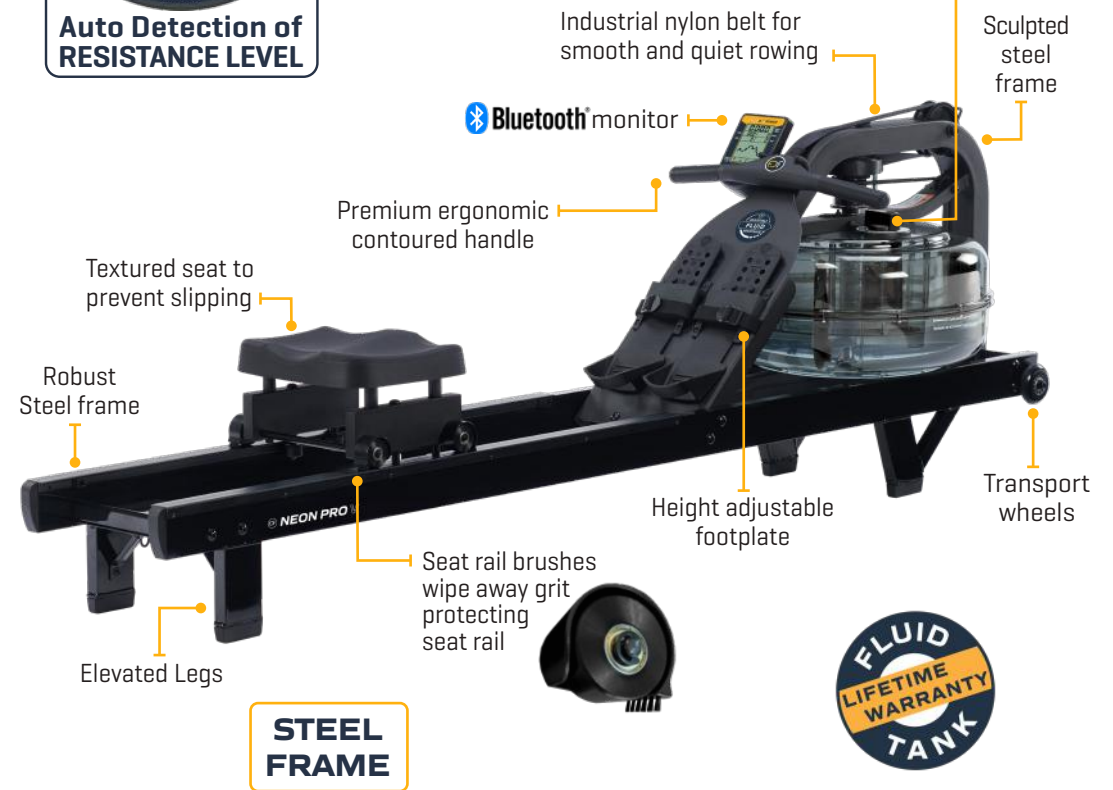

STEEL FRAME

View the full range of rowers at FLUIDROWER.COM
Visit FDFLIMITED.COM to view all FDF products ranges.



NEON PRO V BLACK FLUIDROWER

PRODUCT SPECIFICATIONS

PRODUCT MODEL NO:	EPBV
FLUID RESISTANCE:	FDF Horizontal V Twin Tank - 5 Levels
MONITOR:	FDF  Bluetooth / Heart Rate Compatible
PRODUCT NET WEIGHT:	39.14kg [86.29lb]
PRODUCT GROSS WEIGHT:	48.94kg [107.89lb]
DIMENSIONS:	L 2,160mm [85.04"] x W 520mm [20.47"] x H 680mm [26.77"]
MIN ACTIVE AREA REQUIRED:	L 3,330mm [131.09"] x W 1,720mm [67.71"]
STORED VERTICAL DIMENSIONS:	L 680mm [26.77"] x W 540mm [21.25"] x H 2,130mm [85.03"]
MAX USER WEIGHT:	150kg [330lb]
COMMERCIAL WARRANTY:	Frame 10 years - Polycarbonate Tank & Seals - Lifetime Warranty Mechanical & Other Non-Wearing Components - 2 Year Limited Warranty All Other Components (of a wearing nature) - 1 Year Limited Warranty Refer to website for full warranty terms and conditions.



CONSOLE FEATURES

- +  Bluetooth Connectivity using BT FTMS protocol
- +  Bluetooth Heart Rate Monitor (HRM) compatible
- + Auto start
- + Time - Elapsed time
- + Level - Auto to selected resistance level
- + 500M Time - Time to row 500 meters
- + Watt - Unit of power per stroke
- + Distance - Updated every second
- + SPM - Strokes per minute
- + Power Graphs - 2 Options
- + Calories burned per hour

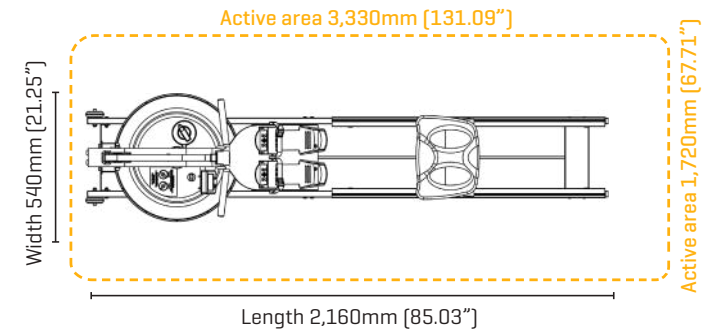

ABOUT FDF LIMITED

FDF Limited is the leader in designing and manufacturing a range of adjustable Fluid Resistance fitness machines for commercial and residential applications. At the heart of the fitness range is the unique and patented Twin Tank Fluid Resistance system. The adjustable Fluid Resistance system challenged conventional thinking of how water could work to provide adjustable resistance rather than just a liquid mass flywheel. The patented Twin Tank system provides silky smooth resistance at any speed and is perfect for cardio training, warm-ups, cool downs, intense HIIT workouts or rehabilitation programs. **FDF Limited** categorizes the range of adjustable Fluid Resistance machines under the banners, **FluidRower**, **FluidExercise** and **FluidPowerZone**, see the adjacent web links. **FDF Limited** products are distributed throughout the globe and are popular in Fitness Centers, Hotels and Apartments, Sporting Clubs, Universities, First Responders, Defence Force Training Facilities and Physical Rehabilitation Clinics.

OPTIONAL FLUIDROWER ACCESSORIES

TOUCH HEART RATE HANDLE



TABLET HOLDER



PHONE HOLDER



SEAT BACK KIT



View all FDF products at FLUIDROWER.com FLUIDEXERCISE.com FLUIDPOWERZONE.com

* FDF reserves the right to modify any product design, manufacture or aesthetic without notice or consultation. Product specifications and warranties may vary from country to country.