

# VORTEX VX-2

## COMMERCIAL FLUIDROWER



# FLUID ROWER



The **FDF Vortex VX-2 FluidRower** integrates the aesthetics of Italian design with the precision of German craftsmanship in a product that delivers exceptional performance and quality. Constructed using lacquered architectural steel, sculpted dual seat rails and with every detail finished to perfection, it represents outstanding value for money.

Our unique Direct Drive design ensures that all you feel, hear and see is the water churning through the tank. It's the closest thing to actual on-water rowing and you will love it! Close your eyes and you could be out on the river.

Adjustable Fluid Resistance at the turn of a lever keeps users challenged, motivated and engaged. Our patented twin tank design delivers a massive range of resistance to suit every rower, from deconditioned seniors to professional athletes and oarsmen. Instantly adaptable to each individual, it encourages progression as fitness levels and abilities improve.

Virtually maintenance free and designed for the toughest, or the most prestigious, of commercial environments, the **Vortex VX-2 FluidRower** delivers at every level. A product this good makes you want to exercise! Make rowing popular in your fitness facility and challenge the status quo.

Vortex Rowing Ergometers part of the FDF premium commercial range.

COMPACT CLASS STORAGE



MODERN SCULPTED STEEL PROFILES



**MINIMUM**      **10** ADJUSTABLE FLUID RESISTANCE LEVELS      **MAXIMUM**

Bluetooth monitor

Industrial nylon belt for smooth and quiet rowing

Premium ergonomic contoured handle

Contoured, non-slip seat

Concealed air glide seat rollers

Robust Steel / Aluminum frame

Office chair seat height for easy entry and exit

Secure adjustable foot straps and heel cups

Transport wheels

**Bluetooth**

**Auto Detection of RESISTANCE LEVEL**

**FLUID LIFETIME WARRANTY TANK**

**STEEL ALUMINIUM FRAME**

View the full range of rowers at [FLUIDROWER.COM](http://FLUIDROWER.COM)  
 Visit [FDFLIMITED.COM](http://FDFLIMITED.COM) to view all FDF products ranges.



# VORTEX VX-2 FLUIDROWER

## PRODUCT SPECIFICATIONS

PRODUCT MODEL NO:	VX-2
FLUID RESISTANCE:	FDF Vertical Twin Tank - 10 Levels
MONITOR:	FDF  Bluetooth / Heart Rate Compatible
PRODUCT NET WEIGHT:	58.00kg [127.87lb]
PRODUCT GROSS WEIGHT:	69.20kg [152.56lb]
DIMENSIONS:	L 2,050mm [80.71"] x W 810mm [31.89"] x H 1,005mm [39.57"]
MIN ACTIVE AREA REQUIRED:	L 3,250mm [127.95"] x W 2,010mm [79.13"]
STORED VERTICAL DIMENSIONS:	L 810mm [31.20"] x W 1,005mm [39.57"]
MAX USER WEIGHT:	150kg [330lb]
COMMERCIAL WARRANTY:	Frame 10 years - Polycarbonate Tank & Seals - Lifetime Warranty Mechanical & Other Non-Wearing Components - 2 Year Limited Warranty All Other Components (of a wearing nature) - 1 Year Limited Warranty Refer to website for full warranty terms and conditions.



## CONSOLE FEATURES

- +  Bluetooth Connectivity using BT FTMS protocol
- +  Bluetooth Heart Rate Monitor (HRM) compatible
- + Auto start
- + Time - Elapsed time
- + Level - Auto to selected resistance level
- + 500M Time - Time to row 500 meters
- + Watt - Unit of power per stroke
- + Distance - Updated every second
- + SPM - Strokes per minute
- + Power Graphs - 2 Options
- + Calories burned per hour

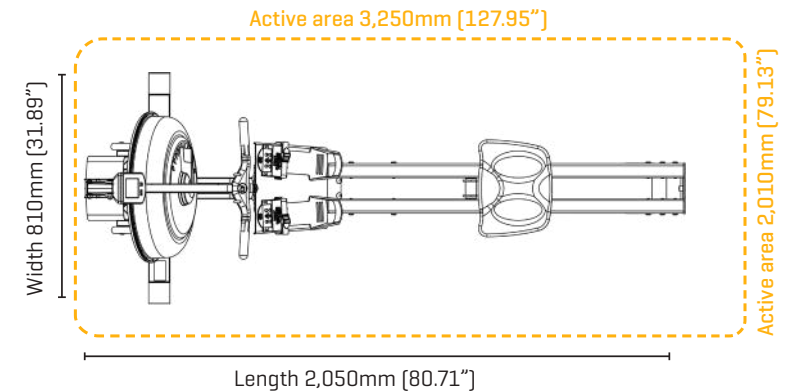

## ABOUT FDF LIMITED

**FDF Limited** is the leader in designing and manufacturing a range of adjustable Fluid Resistance fitness machines for commercial and residential applications. At the heart of the fitness range is the unique and patented Twin Tank Fluid Resistance system. The adjustable Fluid Resistance system challenged conventional thinking of how water could work to provide adjustable resistance rather than just a liquid mass flywheel. The patented Twin Tank system provides silky smooth resistance at any speed and is perfect for cardio training, warm-ups, cool downs, intense HIIT workouts or rehabilitation programs. **FDF Limited** categorizes the range of adjustable Fluid Resistance machines under the banners, **FluidRower**, **FluidExercise** and **FluidPowerZone**, see the adjacent web links. **FDF Limited** products are distributed throughout the globe and are popular in Fitness Centers, Hotels and Apartments, Sporting Clubs, Universities, First Responders, Defence Force Training Facilities and Physical Rehabilitation Clinics.

## OPTIONAL FLUIDROWER ACCESSORIES

TOUCH HEART RATE HANDLE



TABLET HOLDER



PHONE HOLDER



SEAT BACK KIT



View all FDF products at [FLUIDROWER.com](http://FLUIDROWER.com) [FLUIDEXERCISE.com](http://FLUIDEXERCISE.com) [FLUIDPOWERZONE.com](http://FLUIDPOWERZONE.com)

\* FDF reserves the right to modify any product design, manufacture or aesthetic without notice or consultation. Product specifications and warranties may vary from country to country.